

OPERATORS MANUAL

MODELS TM-TMP 32/98 - 114 TMP 130

“TRANSLATION OF THE ORIGINAL MANUAL”

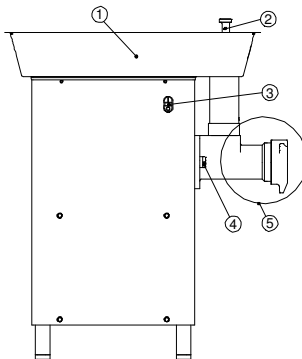
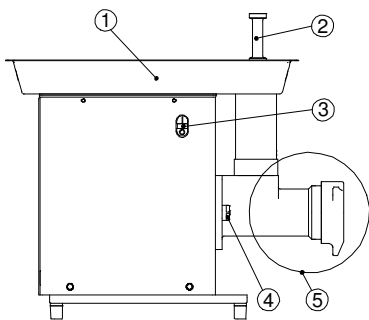

1. Tray
2. Pusher
3. Switch
4. Worm casing fixing Nut
5. Worm Casing Group
6. Worm Casing
7. Worm
8. Cutter
9. Plate
10. Nut
11. Worm Casing Sleeve

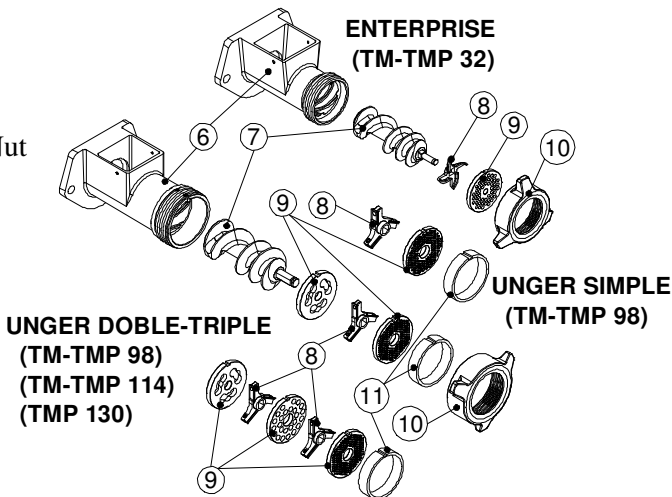

BRAHER INTERNACIONAL S.A. AVDA CARLOS I, 14- 1º C • 20011 SAN SEBASTIAN-ESPAÑA

1.-MACHINE DESCRIPTION

The machine is a mincer used for transforming pieces of fresh meat into minced meat. It has a tray (1) where the meat to be minced is placed, with a hole through where the meat pieces are introduced towards the worm-casing (6). In this point takes place the mincing process by a worm (7) that sends the meat towards the blade (8) which cuts it, and the hole plate(s) (9). The meat, already minced, goes out through these holes.

2.-SAFETY INSTRUCTIONS

On the worm casing of the meat mincer, the diameter of the holes on the last plate must be < 8 mm. The thickness of the last plate must be < 5 mm. In case of damage, no responsibility would be accepted for the non-compliance of the above point.

The meat mincer is equipped with some safety devices in order to prevent hazards:
“NOTE: It is very important to verify that all the safety devices (electric and mechanic devices detailed below) perform correctly before starting a new working day.”

2.1.-ELECTRICAL DEVICES: (CE models)

1. The push buttons (3) are working on safety low tension.
2. When the power is restored after a power interruption or when an interlock switch is remade the machine does not automatically start. It is necessary to restart the machine by pressing the on switch (3).
3. The ground wires, coloured green and yellow, have the same section as the wires with bigger section of the machine.
4. The electrical elements situated inside the machine housing are protected according to IP 33. The electrical components situated outside the machine are protected according to IP 67.

2.2.-MECHANICAL DEVICES:

1. There is a protection element at the tray (1) which avoids the fingers to arrive to the worm (7) in case the hand could be accidentally introduced through the tray hole.
2. A plastic pusher (2) is supplied with every machine. The operator has to use this element for introducing the meat without risk.

2.3.-SYMBOLS



It is obligatory to read the entire instruction manual before any operation on the machine.



Machine according to the Directive 2006/42CE (the machines sold at the European Community).



Do not use a jet water source for washing the machine.

3.-INSTALLATION

3.1.-INSTALLATION IN THE WORK PLACE

The mincer should be installed on a work surface that has enough stability and strength to support the weight of the machine.

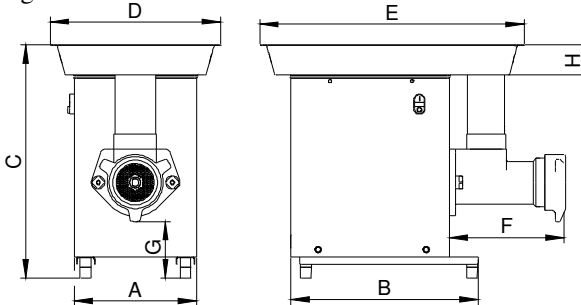

	A	B	C	D	E	F	G	H
TM 32	280	450	580	410	610	254	120	77
TM 98						282		
TM 114	330	505	625	460	710	310	140	82
TMP 32	450	550	1100	600	860	254	570	150
TMP 98						282		
TMP 114						310	550	
TMP 114 (*)						310	710	
TMP 130	520	620	1195	670	985	390	600	150

(*) TMP 114 with special height

3.2.-ELECTRICAL CONNECTION WARNING!

1. Make sure that the line voltage of your main power source matches the rated voltage of the machine, which appears in the rating plate.
2. The outlet plug should remain at a height from the floor in between 0'6 and 1'9 m. and at sight for the operator to easy check if the machine has been unplugged before cleaning it.
3. Always plug the machine to a grounded outlet.
4. Do not turn on the slicer if the cable or plug is damaged.
5. The fuse in the outlet plug must have between 3 and 16 amperes
 Moteur II 3Cv: Connection 230V. 12 Ampères.
 Moteur III 3Cv: Connection 230V. 9,2. Amperes. Connection 400V.: 5,3 Amperes.
 Moteur III 5,5Cv: Connection 230V. 15,7 Amperes. Connection 400V. 9, 1 Amperes.
 Moteur III 7,5Cv: Connection 230V. 21, 3 Amperes. Connection 400V. 12, 3 Amperes
6. The machine must be connected to a leakage current breaker.
7. At three-phase models, if it is necessary a change of voltage, from 400v. to 230v. or vice versa, see section 10.
8. At three-phase models, it is necessary to check the sense of rotation as the correct one, so that it should be the opposite sense as of the clock, as shown in the signals on the front of the machine; if this is not correct, there should be a change made to the phases of the plug in order to change the sense of rotation.

4.-OPERATION WARNINGS

- 1. Do not try to turn on the machine without learning before how to operate it.**
- 2. Never make the machine work empty, for avoiding the premature damage of the hole plate and the cutter, which should affect to a good mincing process.**
- 3. If several hole plates are used, they must be coupled with their correspondent cutter; do not interchange this elements as the mincing quality should be affected.**
- 4. This machine allows mincing only fresh meat.**
- 5. Operation conditions:** Temperature: 5-40°C / Humidity: 30-95%
- 6. Check that the worm casing and the nut (4) is well clamped before starting the meat mincer.**

4.1.-MINCING OPERATION:

1. Position a tray or a paper under the worm casing group (5) of product exit.
2. Remove the pusher (2) and put the meat at the tray hole (1).
3. Press on the white On switch (3) (or turn the switch, depending on the models). The mincer starts to work.
4. Use always the pusher (2) for helping the meat to introduce by the tray hole (1)..
5. After having minced the desired amount of meat press the red off switch (3) (or turn the switch on the opposite side, depending on the models), for stopping the meat mincer.

WARNING: Never overload the machine.

5.-MAINTENANCE AND CLEANING

WARNING: The machine must be turned off and unplugged for cleaning and maintenance operations.

Use a damp cloth in detergent to clean the machine. Never use any chemical or abrasive products. Do not use a brush or any other type of utensils that could damage the different pieces of the mincer. Thin and dry..

For a good cleaning it is necessary to remove the worm casing group (5) and its elements following the instructions of this chapter.

5.1.-WORM CASING GROUP (5) AND ELEMENTS DISASSEMBLY:

WARNING: The machine must be turned off and unplugged.

1. Unscrew the nut (4) with the special key (12) that is provided with the machine. (See at the drawing 5).
2. Remove carefully the Group outside.
3. Unscrew the nut (10), take the sleeve (11) and use the special key (12) to take carefully the plate (9), the cutter (8) and the worm (7). (See drawing 5).

5.2.-WORM CASING GROUP (5) AND ELEMENTS ASSEMBLING:

1. Fix the worm casing (6) and fix it with the nut (4) with the special key (12).as shown in the drawing:
2. Introduce the worm (7).
3. Put the inner hole plate (9), cutting face (hole's narrower side) against the cutter, not the other way.
4. Put the cutter (8).
5. Put the external hole plate (9).
6. Repeat steps 4 and 5 in the triple cut version.
7. Put the sleeve (11).
8. Place the Nut (10) screwing on counter clock wise.

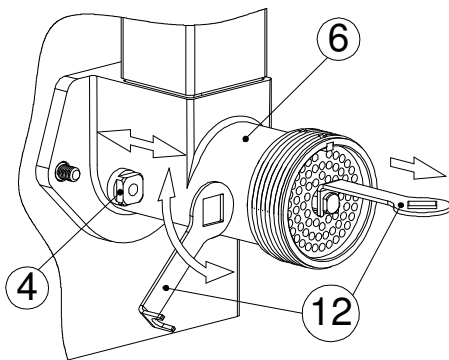

IMPORTANT WARNING: In this operation, the Nut (10) must be clamped carefully, without straining, for avoiding a premature deterioration of the hole plate and cutter due to an excess of pressure (best plates and cutters manufacturers recommendation).

5.3.-CLEANING FREQUENCY:

To guarantee a maximum hygiene level, it is necessary to clean all the parts in the contact food area every day. Make sure to clean the machine completely at least once a week. Cover the mincer with a clean cloth once you have finished cleaning it.

6.-TROUBLE SHOOTING

6.1.-Problem: The mincer does not start.

1. Verify there is current at the plug...
2. Verify the plug voltage with the mincer voltage characteristic plate.
3. In affirmative case of these points, call the distributor authorised.

6.2.-Problem: A slow start of motor or overheat.

1. Verify the plug voltage with the machine voltage characteristic plate.
2. In affirmative case call the distributor authorised.

6.3.-Problem: Blade does not mince enough.

1. Verify that the blade and the plate are not worn out. If not, proceed to substitute both parts (never interchange plates or cutters worn out with new ones).
2. Verify that the worm (6) has been introduced correctly towards the end of its place in the machine, and the nut (10) pressing the sleeve (11) but not on the worm (6).
3. In this operation, the Nut (10) must be clamped carefully, without straining, for avoiding a premature deterioration of the hole plate and cutter due to an excess of pressure, and a bad mincing finish of the product.

7.-SOUND LEVEL

The mincer maintains an acoustic level under the 70 decibels.

8.-LIABILITY

No liability will be accepted when the damages are caused by inadequate use, defective handling, structural modifications, removal of the protection devices or use of spare parts that are not from the manufacturer. The seller will not be liable to the buyer when the damages are caused to a natural wear out of the machine.

9.-TECHNICAL SPECIFICATIONS:

Motor: TM-TMP 32/98:	II:	3 cv.	230/400v..	50Hz.
	III:	3 cv.	230/400v..	50Hz.
TM-TMP 114:	III:	5, 5 cv.	230/400v.	50Hz
TMP 130:	III:	7, 5 cv.	230/400v.	50Hz

ATTENTION: These specifications could change for some countries due to special voltages. Verify the rating plate of the machine before plugging it.

Safety:

1. Protection at the tray hole (1) and pusher (2) for helping to introduce the meat by this tray hole.
2. 24 v. plate low tension, On-off switch and no volt release in CE models.

Finish: 18/8 stainless steel.

MOD.	TM	TM 98	TM 114	TMP 32	TMP 98	TMP 114	TMP 130
Worm casing diameter mm	100	98	114	100	98	114	130
Hourly production (Kg./h)	750	750	1.100	750	750	1.100	1.500
Net weight, Kg.	80	80	93	115	115	121	160

NOTE: The specifications could be changed without prior notice.

10.-ANNEX FOR TECHNICAL SERVICE: THREEPHASE VOLTAGE CHANGING

WARNING: The machine must be turned off and unplugged, before this operation.

To change from 400v. to 230v. or from 230v. to 400v., proceed as follows:

1. The tray must be removed, unscrewing the four screws (13) shown at the drawing:
2. At the engine exit, change the connector 400 V by 230V. or vice versa according to the desired voltage. See the wiring diagram of page 8.
3. At “CE” models, change the connector 400V. by 230V. or vice versa according to the desired voltage. See the wiring diagram (page 8).
4. Place the tray fixing the four screws (13).

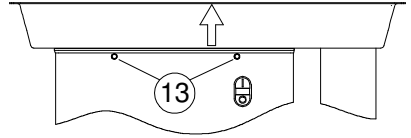

IMPORTANT WARNING: The motor and plate must be connected at the same voltage.

After the change, the new voltage must be marked in the place of the old one in the characteristic plate.

WIRING DIAGRAM II

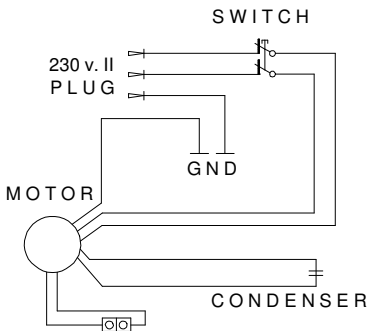

WIRING DIAGRAM III

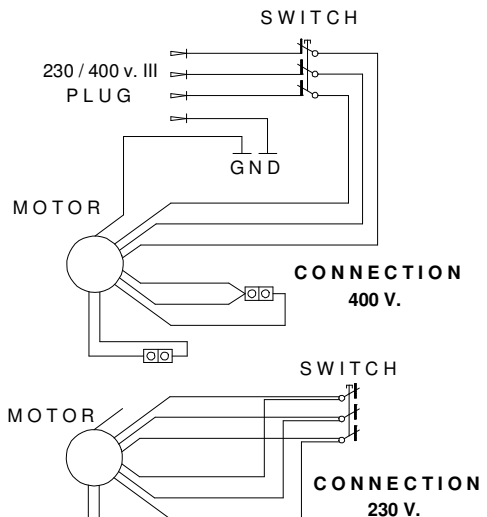

WIRING DIAGRAM II CE MODEL

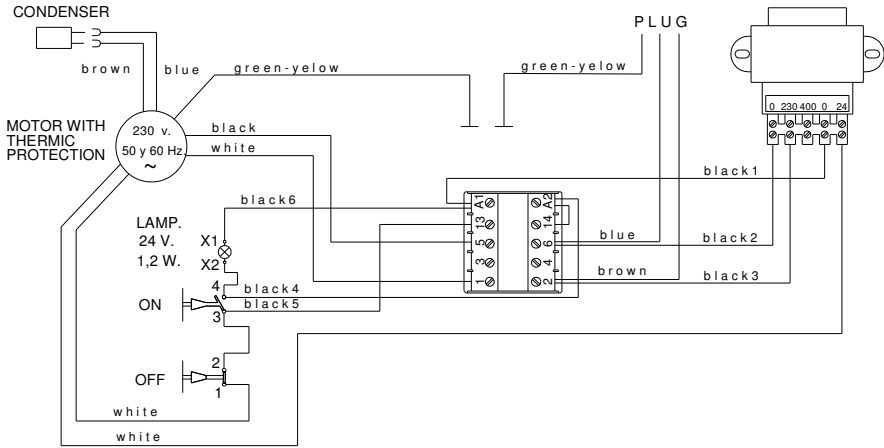

WIRING DIAGRAM III CE MODEL

CONNECTION 230V.

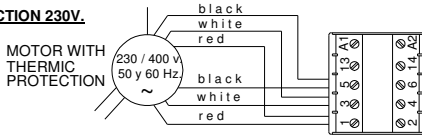

CONNECTION 400V.

